

ロックユニットソレノイド

LockUnit SOLENOID

 **新電元**
SHINDENGEN

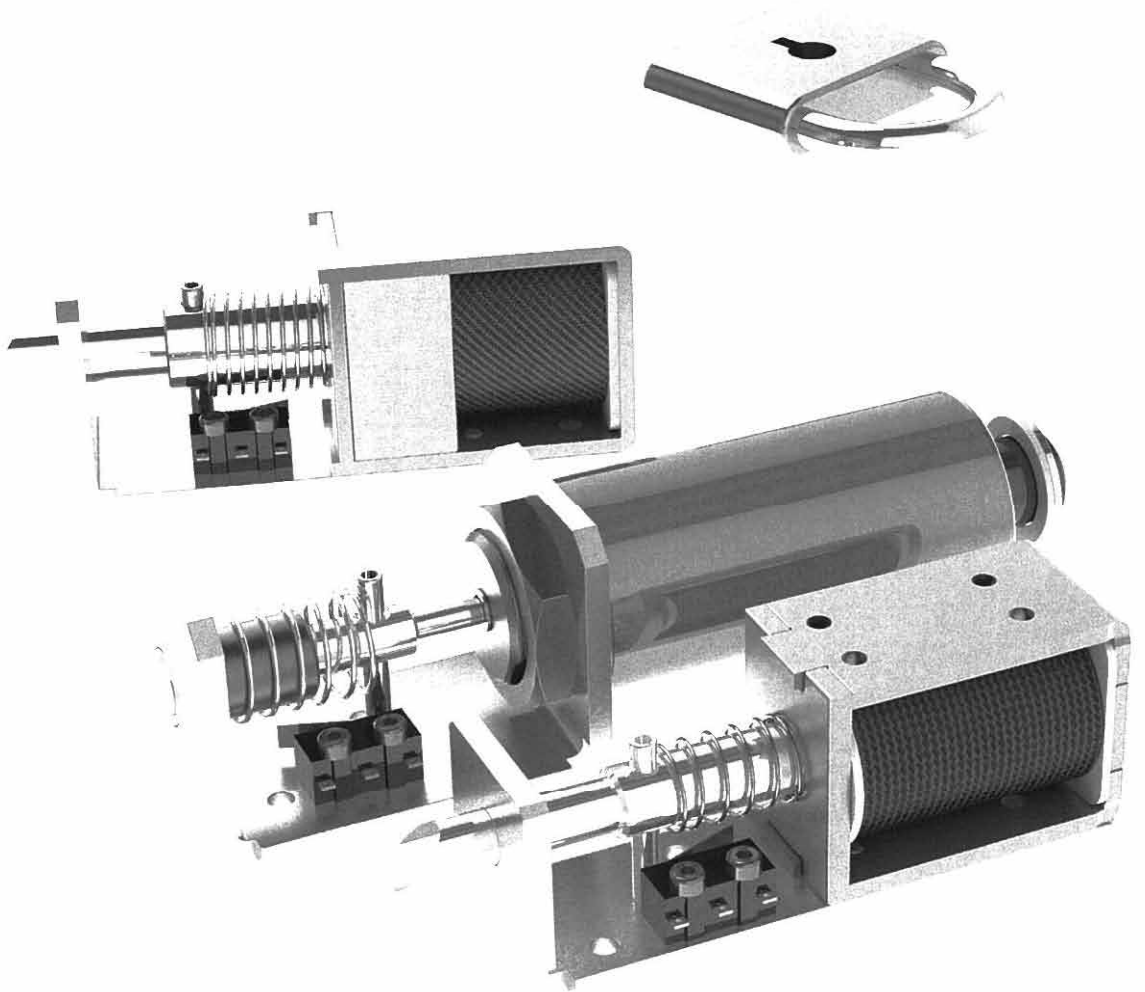

CONTENTS

Lock Unit SOLENOID

LU26KC 1

LU31TO 2

LU32HC 3

OPTIONAL 4

POINTS OF CONCERN ON USE OF THIS CATALOG . . 5

LU26KC Lock Unit SOLENOID

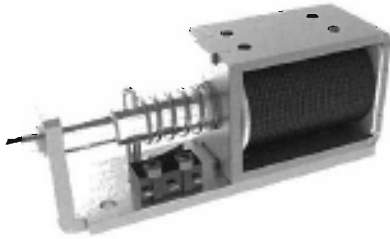

Features

Normal Close (Automatic Locking) Type
 Unlocked when solenoid is energized.

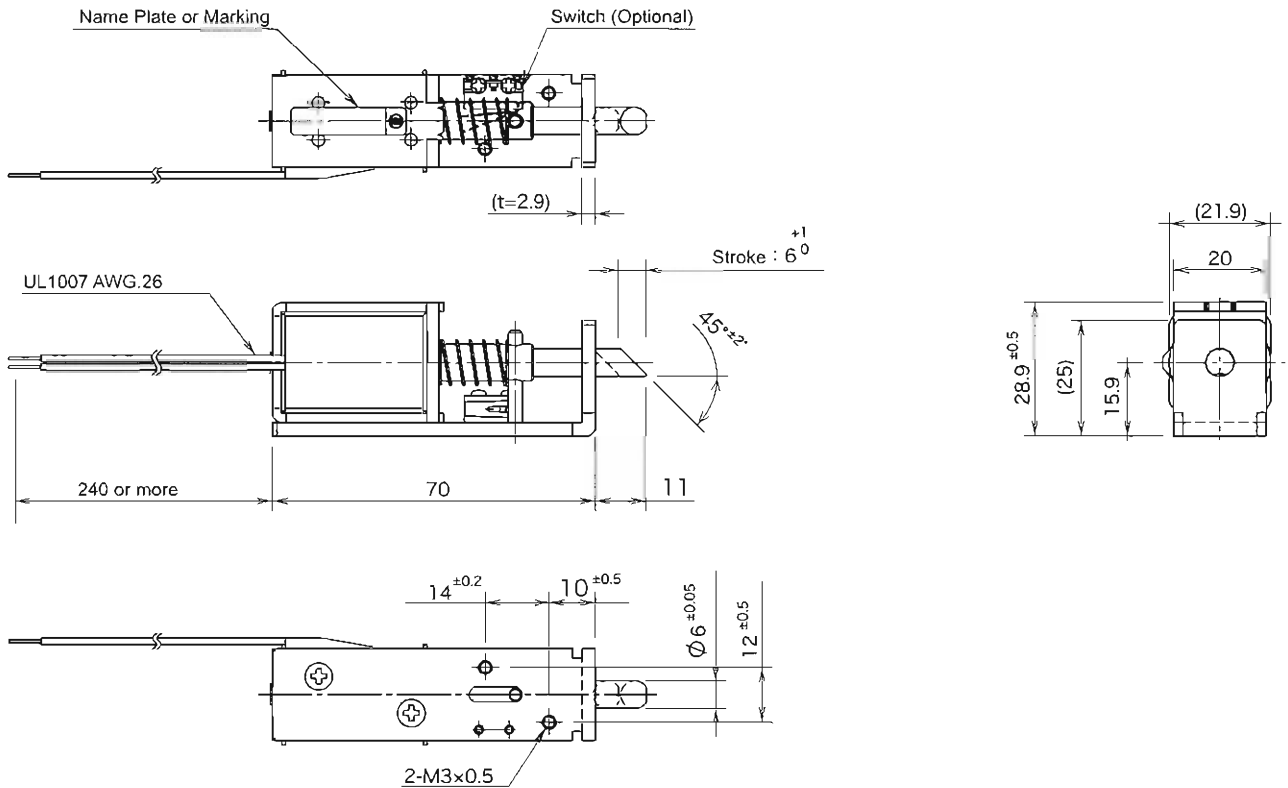

Weight: 145 g

Type	Rated Voltage (V)	Coil Resistance (Ω) at 20°C	Power Consumption (W)	Attraction Force (When excited)	Holding Force (Spring Force)
LU26KC-12	12	36	4.0	0.4	0.7
LU26KC-24	24	144	4.0	0.4	0.7

General Characteristics

- Insulation Class: Class A (105°C)
- Withstand Voltage: AC 1200 V 50/60 Hz 2 Seconds (ordinary Temperature/ Humidity)
- Insulation Resistance: at DC 500 V megger 100 M Ω or more (ordinary Temperature/ Humidity)
- Expected Life: Three hundred thousand times

Cautions when using the product

- All data was obtained at ambient temperature of 20°C with the product horizontally installed.
- The product is designed so that temperature rise of the coil does not exceed 65°C when continuously energized at the rated voltage shown above.
- This allows use up to an ambient temperature of 40°C.
- When continuously energized, the solenoid becomes hot. If there is a risk of it being touched, measures should be taken to prevent burns.
- Make sure that no load is applied to the latch rod during the energizing operation.
- Energizing polarity does not affect the motion of the solenoid.

LU31TO Lock Unit SOLENOID

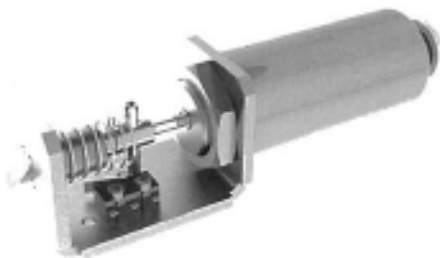

Features

- Normal Unlock Type
- Locked when solenoid is energized.

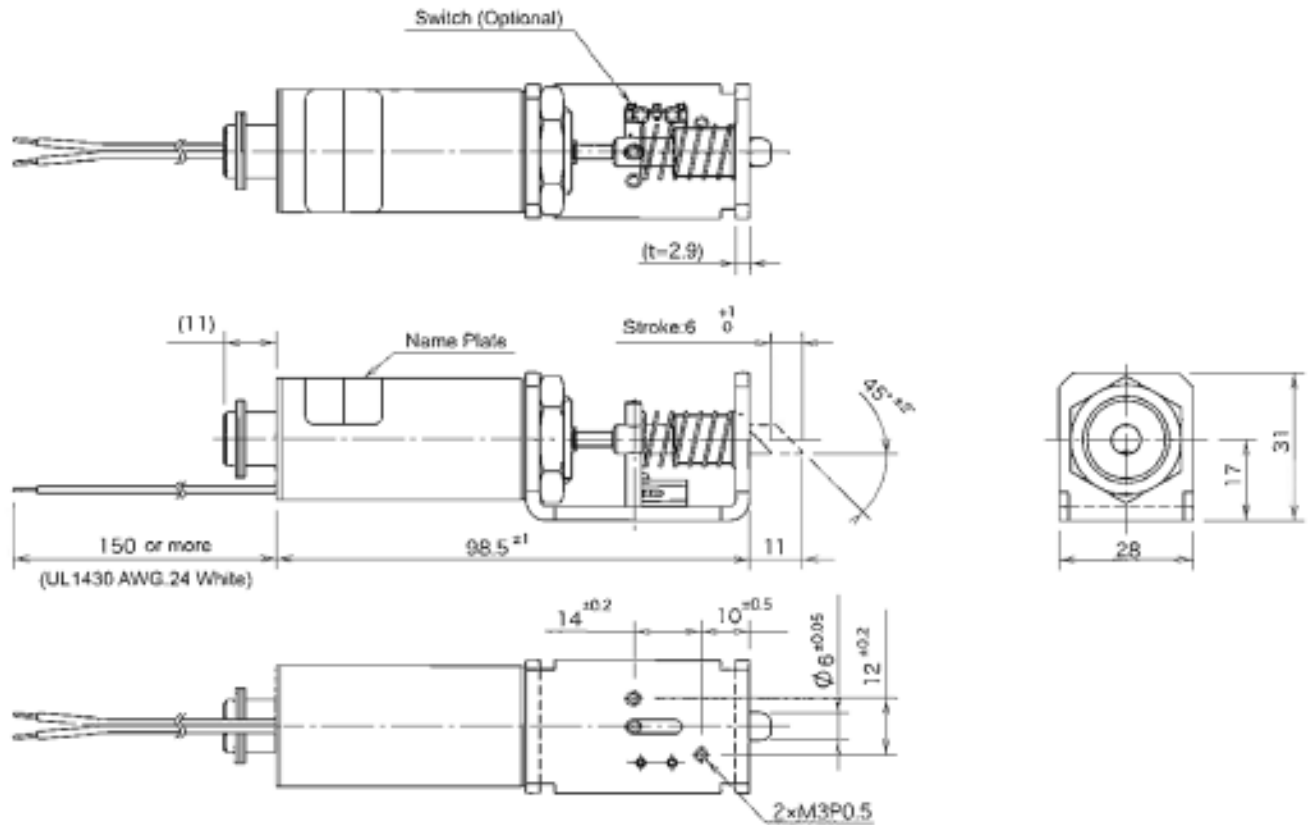

Weight: 255g

Type	Rated Voltage (V)	Coil Resistance (Ω) at 20°C	Power Consumption (W)	Attraction Force (When excited)	Holding Force (Spring Force)
LU31TO-12	12	17	8.5	1.6	1.2
LU31TO-24	24	66	8.5	1.6	1.2

General Characteristics

- Insulation Class: Class E (120°C)
- Withstand Voltage: AC 1200 V 50/60 Hz 2 Seconds (ordinary Temperature/ Humidity)
- Insulation Resistance: at DC 500 V megger 100 MΩ or more (ordinary Temperature/ Humidity)
- Expected Life: a million times

Cautions when using the product

- All data was obtained at ambient temperature of 20°C with the product horizontally installed.
- The product is designed so that temperature rise of the coil does not exceed 100°C when continuously energized at the rated voltage shown above.
- This allows use up to an ambient temperature of 40°C.
- When continuously energized, the solenoid becomes hot. If there is a risk of it being touched, measures should be taken to prevent burns.
- Make sure that no load is applied to the latch rod during the energizing operation.
- Energizing polarity does not affect the motion of the solenoid.

LU32HC Lock Unit SOLENOID

Features

Energy Efficient and Self-Holding Normal Lock Type.
Solenoid is energized only during operation.

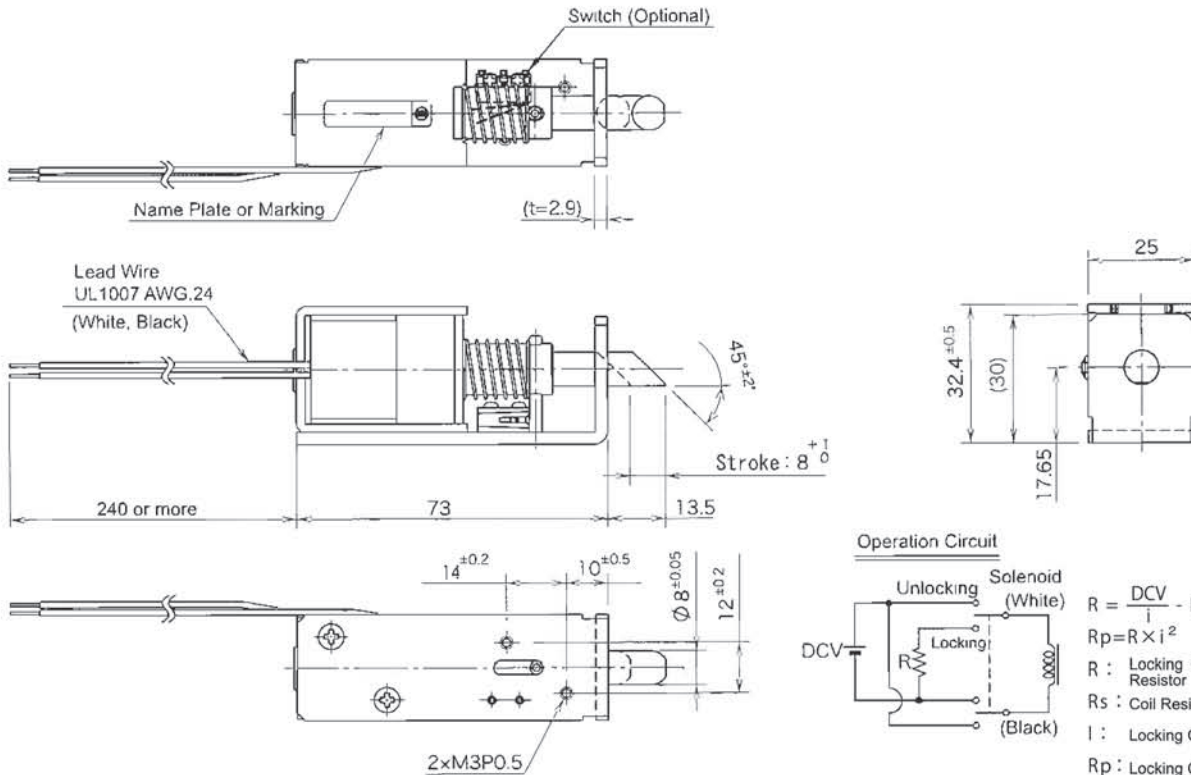
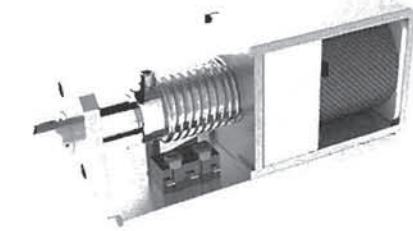

Operation Circuit

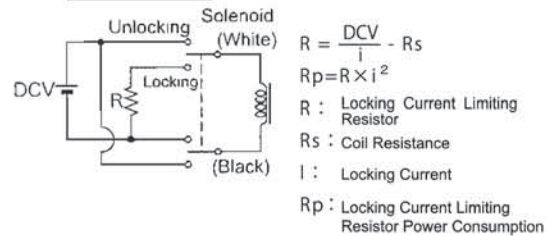

Weight: 215g

Type	Rated Voltage (V)	Coil Resistance (Ω) at 20°C	Power Consumption (W)	Attraction Force (N)	Holding Force (N)	Locking Current (mA)
LU32HC-12	12	7.8	18.4	1.6	1.3	820
LU32HC-24	24	31.3	18.4	1.6	1.3	400

* Use the product under the following conditions. Duty Cycle: ≤25%, Maximum ON Time: ≤20 sec.

General Characteristics

- Insulation Class: Class A (105°C)
- Withstand Voltage: AC 1200 V 50/60 Hz 2 Seconds (Ordinary Temperature/Humidity)
- Insulation Resistance: at DC 500 V megger 100 MΩ or more (Ordinary Temperature/Humidity)
- Expected Life: Two hundred thousand times

Cautions when using the product

- All data is obtained at ambient temperature of 20°C with the product horizontally installed.
- This self-holding lock unit solenoid can hold each position without power only by energizing when it is unlocked / locked.
- Make sure that energization is within maximum power ON time and the duty cycle is within 25% in case of continuous operation.
- Make sure that no load is applied to the shaft during the energizing operation.
- Note that the coil has polarity.

OPTIONAL

We can provide installation of the switch for an operation check and structural change to models that match various use environments.

Pictures are the typical examples. In addition to these products, Shindengen Mechatronics can offer longer-life models, installation of temperature fuses, and waterproof models.

Shindengen Mechatronics is ready to respond to customer. Please feel free to contact us.

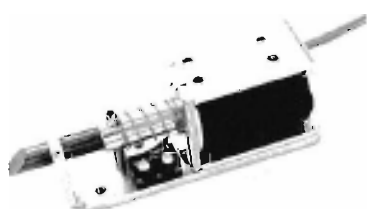

Installation of switch for operation check



Improved Thrust Type Solenoid



Change of nose shape of latch rod

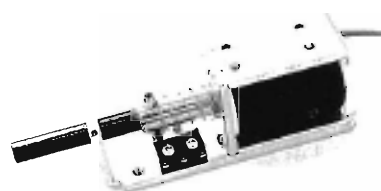

Waterproof Coil Model



Change of direction of latch rod

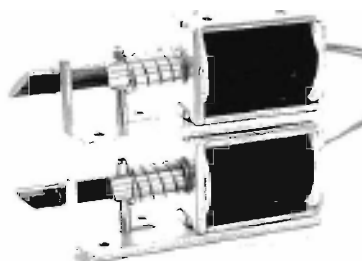

POINTS OF CONCERN ON USE OF THIS CATALOG

1. Technical information described in this catalog explains specifications, characteristic diagrams, dimensional outline drawings, and general operation of our solenoids, selection of our models, and cautions in handling.
2. Reference circuit programs described in this catalog are intended to provide adequate understanding of performance of our solenoid. Therefore, they do not guarantee output characteristics, temperature characteristics, other characteristics, characteristics established by public agencies, and safety.
3. Our lock unit solenoids described in this catalog are designed for general electronic devices and general industrial use. Pay attention to ensure security and reliability according to importance of your system. Do not use products to lock anything especially in a place where security is emphasized.
4. Do not use products for applications where an extremely high level of reliability and safety are needed, such as use for nuclear control, aerospace, traffic control, or life support-related medical equipment. Malfunctions and accidents could directly threaten the human body or human life. If there are any questions, please contact our sales department.
5. Do not touch the solenoid directly! Moving parts can catch your fingers during a power application. Some parts remain hot during energization or just after stopping, which may cause burn injuries.
6. Solenoids do not have a built-in fuse on the input line. A fuse must be inserted into an input line to prevent smoking or fires in the event of failure of the solenoid.
7. Our company is not responsible for the technical data described in this catalog, any damage caused by usage of reference circuit programs, and infringement of patent rights or any other rights.
8. This catalog does not guarantee or grant intellectual property or any other rights by our company or a third party.
9. Our solenoids described in this catalog are unrelated to items listed in 1 to 15 of the appended Table 1 of the Export Trade Control Order and are exempt from the List Control. However, they are listed in 16 of appended Table 1 of the Export Trade Control Order and are subject to the Catch-All Control. If products are goods or technologies controlled by the Foreign Exchange Law and the Export Trade Control Order, it is necessary to apply for an export license.
10. Specifications and dimensions of our solenoids described in this catalog may be changed without prior notice due to characteristic improvements. In placing an order, please contact our sales department as necessary to refer to the latest specifications of individual products.
11. Transcribing or duplicating part or all of this catalog without permission from our company is prohibited.

●Please contact the address below for clarification of details and order.

Shindengen Mechatronics Co.,Ltd. <http://smt.shindengen.co.jp>

11-8 Inari-cho, Hannou-city, Saitama 357-0037 Japan TEL: +81-42-971-6212 FAX: +81-42-971-6218

■The contents described in this catalog may be changed without prior notice due to improvements.

As of June, 2014

Shindengen Mechatronics Co., Ltd

<http://smt.shindengen.co.jp>

Head Office 11-8 Inari-cho, Hannou-city, Saitama 357-0037 Japan

TEL: +81-42-971-6212 FAX: +81-42-971-6218

Please feel free to contact us if you are interested in our products.

Printed In Japan (SNC)

Magnetic Technology & Quality



Shindengen Mechatronics

新電元メカトロニクス